

The User Manual

1550nm CATV ERBIUM-DOPED FIBER AMPLIFIER



Our module light pumped laser and Erbium-Doped Fiber is used by the original binding component from USA.

We have reliable optical light power output stabilizing circuit and laser electrical refrigerator temperature to control the circuit, guaranteed the complete machine optimum performance and the laser long life steady work..

The microprocessor software have laser condition monitor, digital display fault warning, network management and various function. Once the laser's operational parameter deviate software establishes permission scope, it will close laser's power automatically. The red light coruscate, prompt alarm and digitizing tablet will point out fault cause.

The microprocessor software provide RS-232 and 485 interface used for network management and remote monitoring.

We adopt 1RU 19" standard engine frame efficient switch power, 85~254V utility power.

This manual applies to the **E-1550 series 1550nm bait doped fiber amplifier; focuses on the performance of the product features, installation and commissioning, technical parameter and common troubleshooting and other related content. In order to make sure that the device is installed and security runs smoothly, please user in the installation and commissioning of this

device, be sure to read this manual carefully and strictly in accordance with the manual steps to install debugging, so as not to cause unnecessary damage to equipment, operations or causing accidental injury; if you have any questions, please contact our company.

Special hints

- Bait doped fiber amplifiers is a high-end professional equipment and its operation of the installation must be performed by professionals, and read this manual carefully before operating, in order to avoid damage to equipment due to misunderstood operation, or causing accidental injuries to operators.
- When working in optical fiber amplifier, located at the rear panel of the optical signal output adapter will have invisible laser beam shooting out the optical signal output port should be avoided on the human body, outlet should not look directly at the light with the naked eye, so as not to cause permanent harm to the human body, the human eye!!!
- Equipment in power before, should first confirm that the earth terminal of the Cabinet and the power outlet is reliable earthing (grounding resistance should be $4\ \omega$), in order to avoid static damage to the laser device and prevent the Cabinet charged that cause harm to the human body.
- To ensure device can long-term stability of work, in voltage does not stability or voltage waveform poor of area, recommendations user for device configuration dedicated of exchange regulator power, has conditions of user more can configuration does not continuous regulator power (UPS) system; in environment temperature changes too large or room environment poor (device of ideal work environment temperature for $25\ ^\circ\text{C}$) of area, recommendations user for device configuration dedicated of air conditioning system, to improved device of work environment.

I. Product overview

Is mainly used in **E-1550-series 1550nm optical fiber amplifier 1550 important optical relay transmission in optical fiber communication system equipment, mainly for image signal, digital TV signal, telephone voice signals and data (or compressed data) ultra long haul transmission of signals. The product selection of imported high-performance baits fiber, the international famous brand low-noise pump laser, and built-in sound embedded automatic monitoring and control system, ensure the machine excellent performance indicators.

II. Performance characteristics

- Selection of international famous brand of low-noise pump laser, low distortion, wide band, high output light power

- Adopts imported high-performance baits fiber, high energy conversion efficiency.
- Power and pumped lasers of all kinds of work status, ensuring a stable optical output power, and effectively extend the working life of the pump laser.
- Front panel in-line blue screen 160*32 dot-matrix LCD display, displaying precisely the status of equipment parameters.
- 19 "rack 1U high standard, equipped in conformity with standard Ethernet interfaces IEEE802.310Base-T and RS-232 interfaces, can facilitate the realization of network monitor.
- Full support for 《 GB/T 20030-2005 management system of HFC network equipment specifications》

III. Schematic diagram of

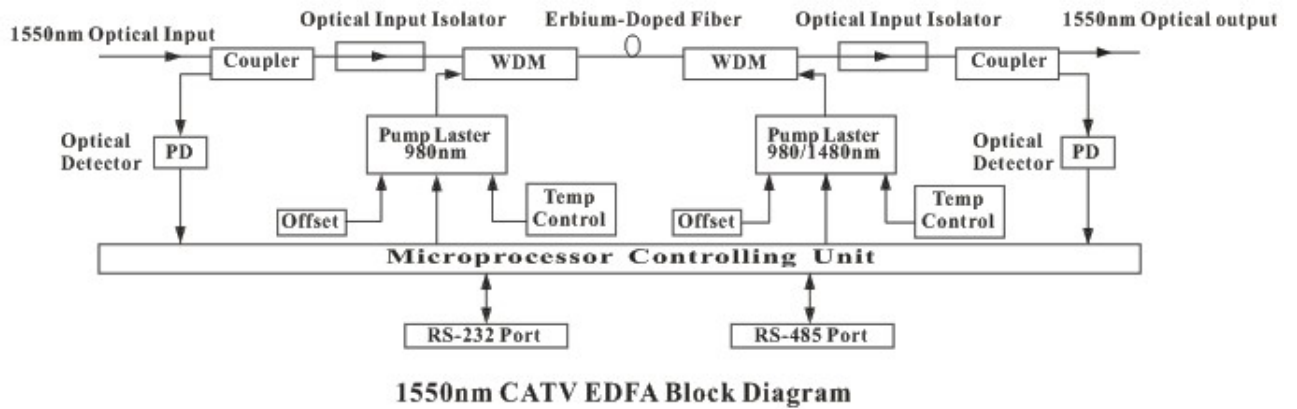

IV. Technical parameters

4.1 link test conditions

Special Note: equipment technical parameters given in this manual is a reference to GY/T 184-2002 the Jeep analog fiber amplifier test methods under the technical requirements and methods of measurement, measured and, under the following test conditions.

Test conditions: and standard fibre and standard light receiver composition test chain road, and in provides of chain road loss conditions Xia, in 550MHZ frequency range within configuration 59 a PAL-D simulation TV channel signal, in 550MHZ-862MHZ frequency range within transfer digital modulation signal, digital modulation signal of level (8MHZ bandwidth within) than simulation signal of carrier level low 10Db, light receiver entered power for -1dBm Shi, measurement carrier combination three order poor took than (C/CTB), and Carrier combo the second beat of the street (C/CSO) and carrier to noise ratio (C/N).

4.2 technical data sheet

Project	Unit	Technical parameters	Notes
Bandwidth	Nm	1535-1565	
Input power range	dBm	-3-+10	Recommended input optical power 0-+5dBm
Output optical power	dBm	13-24	
Output power stability	dBm	±0.5	

Noise figure		dB	≤ 5.0	Input optical power 0dBm
Reflection loss	Input terminal	dB	≤ 45	
	Output terminal	dB	≤ 45	
Pump leak power	Input terminal	dBm	≤ -30	
	Output terminal	dBm	≤ -30	
Carrier to noise ratio (C/N)		dB	≥ 52	
Carrier combined third-order beat (C/CTB)		dB	≥ 63	
Carrier comb erjiecha (C/CSO)		dB	≥ 63	
Optical connector type			FC/APC or SC/APC	
Power supply voltage		V	AC160V-250V(50Hz)orDC-48V	
Operating temperature range		°C	-5 - +55	
Maximum operating relative humidity		%	Max 95% no condensation	
Storage temperature range		°C	-30 - +70	
Maximum storage relative humidity		%	Max 95% no condensation	
Overall dimensions		mm	483 (w) x340 (d) x44 (h)	

V. External functional description

5.1 front panel description

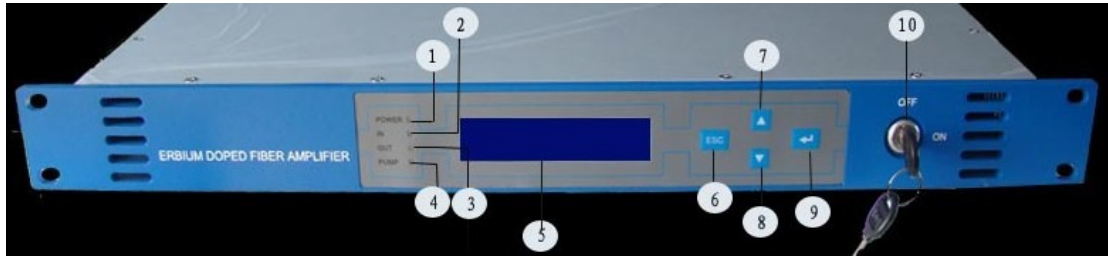

- 1) power indicator: when the lamp is lit when the internal switching power supply.
- 2) input optical power led: input optical power greater than -10dBm the lamp is lit.
- 3) pump working status indicator: when the light is solid red light says pump not working, inside the machine parameters are normal; when the red light flashes, the machine is faulty, related reason for the failure to see the alarm on the display menu menu item; when the light is green light solid pump work properly.
- 4) output optical power led: output optical power is greater than the +10dBm of the light
- 5) 160x32 dot-matrix LCD display: use to display all parameters of the machine
- 6) display settings menu to exit or cancel key.
- 7) displays the Setup menu up or incremental key
- 8) determines the display settings menu key
- 9) pumped laser switch-key: used to control the working state pump lasers. "ON" pump laser opening, "OFF" indicates that the pump laser off. Equipment in power before key in "OFF" position, after device self test passed, according to display a prompt, key twist and turn to the "ON" position.

5.2 rear panel description



- 1) optical signal input: common interface type specifications are both FC/APC and SC/APC.
- 2) optical signal output port: this interface is a device of optical signal output port, interface types FC/APC and SC/APC two of the common specifications. After the equipment normal work, this port is not visible laser beam shot, avoid the ports aligned with the body or to the naked eye, so as to avoid accidental injury.
- 3) RS232 interface: used to configure this computer for the network management parameters.
- 4) LAN interface: IEEE802.3 compliant 10Base-T interface, network management for native
- 5) power input.
- 6) rack Earth Stud: for devices connected to the grounding wire.

5.3 display parameter description

- 1) power on if the lock is turned off is displayed:

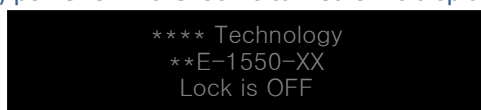

Logo and model of the machine

- 2) unlock the display power-on delay at this time:

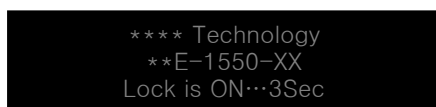

Delay countdown

3) after entering the system displays:

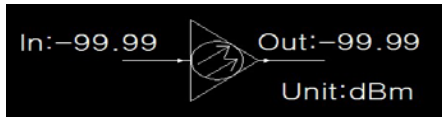

Current input optical power and output optical power

4) if anze ENT button to enter the menu index

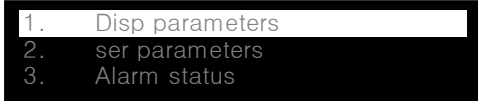

Press up and down arrow keys to highlight bar will move up and down, respectively: **1.** display native parameters menu, **2.** setting can be set to native menu **3.** alarms menu

5) show the parameters of submenu

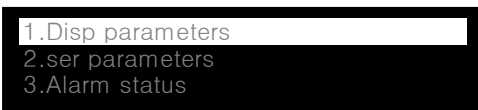

Press the ENT key enters the menu

Displays the contents of the	The significance of
	Current input optical power
	Before the light output of optical power
	X-pump bias current
	X internal pump temperature
	X-th-pumping thermoelectric gas work within current
	Current +5V for voltage
	Current -5V supply voltage
	Native serial number

<pre> +5v Read: 4.78V S/N: Box Temperature: 25.25°C </pre>	The current temperature inside the machine
<pre> S/N: 061103123 Box Temperature: 25.25°C IPAdress: 192.168.0.97 </pre>	The IP address of the machine
<pre> Box Temperature: 25.25°C PAdress: 192.168.0.97 SubnetMask: 255.255.255.0 </pre>	Native to the mask
<pre> IPAdress: 192.168.0.97 SubnetMask: 255.255.255.0 Net Gateway: 192.168.01 </pre>	Native gateway
<pre> SubnetMask: 255.255.255.0 Net Gateway: 192.168.01 Mac: 00-80-95-34-35-55 </pre>	The MAC address of the machine
<pre> Net Gateway: 192.168.01 Mac: 00-80-95-34-35-55 Software Version: 2.00 </pre>	Version number of the software system inside the machine

6) set menu

```

1. Disp parameters
2. set parameters
3. Alarm Status

```

Press the ENT key enters the menu

Display content	The significance of
<pre> Set Optic power Unit Set Buzzer Alarm Set Input OPTPOWER Low Alarm </pre>	Toggles the display of optical power units
<pre> Set Optic power Unit Set Buzzer Alarm Set Input OPTPOWER Low Alarm </pre>	To open or close the buzzer alarm
<pre> Set Optic power Unit Set Buzzer Alarm Set Input OPTPOWER Low Alarm </pre>	Set the input optical power alarm lower bound
<pre> Set Buzzer Alarm Set Input OPTPOWER Low Alarm Set Input OPTPOWER HigSet Optic power Unit </pre>	Set the input optical power alarm limit
<pre> Set Input OPTPOWER Low Alarm Set Input OPTPOWER High Alarm Set out OPTPOWER Low Alarm </pre>	Set the output optical power alarm lower bound

Set Input OPTPOWER High Alarm Set out OPTPOWER Low Alarm Set out OPTPOWER High Alarm	Sets the output light power of alarm limit
Set out OPTPOWER Low Alarm Set out OPTPOWER High Alarm Set Pump Temp Low Alarm	Set the pump temperature alarm lower bound
Set out OPTPOWER High Alarm Set Pump Temp Low Alarm Set Pump Temp High Alarm	Set the pump temperature alarm limit
Set Pump Temp Low Alarm Set Pump Temp High Alarm Set +5V Low Alarm	Set +5V power supply voltage alarm lower bound
Set Pump Temp High Alarm Set +5V Low Alarm Set +5V High Alarm	Setting alarm ceiling +5V power supply voltage
Set +5V Low Alarm Set +5V High Alarm Set -5V Low Alarm	Set -5V power supply voltage alarm lower bound
Set +5V High Alarm Set -5V Low Alarm Set -5V High Alarm	Setting alarm ceiling -5V power supply voltage
Set -5V Low Alarm Set -5V High Alarm Set Fan Control	Set Fan on/off Temp
Set -5V Low Alarm Set Fan Control Set Out Put ATT	Set Optical OutPut ATT
Set Out Put ATT Set Local IP Address Set Subnet Mask	Set the IP address of the machine
Set Local Ip Address Set Subnet Mask Set Gate way	Set up this computer's subnet mask

Set Local Ip Address Set Subnet Mask Set Gate wary	To set up this computer gateway
Set Subnet Mask Set Gate wary Restore Factory Config	Restore factory default settings for the parameters

7) alarm menu



Press the ENT key enters the menu

Network management description

6.1 interface description

1) RS232 communication interface

Native RS232 communication interface standard DB9 female ends as connectors, feet are defined as follows:

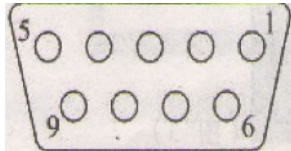

- 1: No Connect 2:TX 3:RX 4: No Connect 5:CND
- 6: No Connect 7: No Connect 8: No Connect 9: No Connect

Native serial communication standard does not return to zero (NRZ) format, 1 start bit, 8 data bits, 1 stop bit, baud rate of 38,400.

2) LAN communication interfaces

LAN communication using standard RJ45 connectors, feet are defined as follows

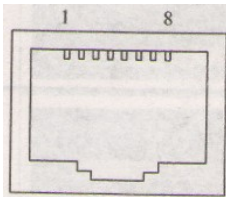

LAN

- 1: TX+ 2: TX- 3:RX+ 4: No Connect 5: No Connect
- 6:RX- 7: No Connect 8: No Connect

6.2 The management and application of network interface

一、 **The transportation feature of category II:**

- 1 Data communication of category II transponder telemetry depends on IP network, it is widely used in LAN, MAN, INTNET, support WLAN、VPN and route。

- 2 Category II transponder telemetry will be needed set the only IP, mask and GW by manual when operating, we do not suggest adopting DHCP

二、 Calibrate:

Debugging should be done in the equipment science.

1 Conditions for debugging:

- 1.1 Optical equipment and transponder telemetry are powered.
- 1.2 Fluently IP network for category II transponder telemetry.
- 1.3 IP resources for category II transponder telemetry have been divided and set up completely.

2 The tools and files for calibrate:

Notebook PC, administrator software (stand-alone version), IP Detect, records for operating and calibrate.

3 Calibrate:

- 3.1 Set up PC IP same with transponder telemetry. The IP for transponder telemetry is 192.168.0.122, the PC can be set 192.168.0.2.
- 3.2 Take off the internet cable of transponder telemetry, connect PC and transponder telemetry with own internet cable, for the internet cable, we can use straight line or cross line. Note: For special PC, it can be only use cross line.

4 Fault judgment:

Phenomenon	Reasons
Parameters error	1、 Data wire can't be connected 2、 Fault for transponder telemetry
Transponder telemetry OFF-LINE	1、 Fault for IP network 2、 Fault for IP, mask and GW. 3、 transponder telemetry crashed 4、 ARP cache is not cleaned out completely.
Transponder telemetry can not be searched IP Detect	The IP of PC and transponder telemetry are not in the same net work section.

Transponder telemetry I Pcan not be revised by IpDetect	The IP of PC and transponder telemetry are not in the same net work section or the mask error
Working parameters can not be foundby adopting generally administrator	Group (read)、Group (write) PUBLIC Uppercase and lowercase inconsistency

VII. Installation and commissioning

7.1 opening checks

1. the equipment in front of the out of the box make sure packaging intact; if outsourcing with damaged or water marks, please contact your local dealer or the carrier immediately.
2. check upon opening the box the packing-slip if requested in accordance with an inventory of equipment and accessories inside the box, if you have any questions please contact your local dealer or call the company.
3. upon opening the box and if you think the device is damaged, do not power on, in order to avoid serious damage to the equipment or cause accidental injury to the operator and immediately contact your local dealer or call the company.

7.2 instrument and tool

1. optical power in mind one
2. digital multimeter;
3. standard fibre test jumper one (FC/APC or SC/APC);
4. ethanol and a number of medical absorbent cotton;

7.3 installation steps

1. before you begin installing the device, please be sure to read the user manual carefully, and according to procedures set forth in the user manual for installation and commissioning. Note: because no can be carried out in accordance with the user manual of practice for installation and commissioning of equipment as a result of man-made damage and all other consequences, our company will not be responsible for any liability or no free warranty.
2. remove the device from its packaging, rack mounted, and reliable grounding device (grounding resistance should be 4 ω).
3. use a digital multimeter to check supply voltage, make sure the voltage is to meet the requirements, and the keys to confirm that the switch is in the "OFF" position, you can power cycle connected devices.
4. under display message, the access light signals, and then rotate the key to switch to "ON" position, observe the status of the front panel led, after the PUMP working condition, such as the light turns green, device access to normal working condition. At this point you can press the menu button on the front panel to view the operating parameters of the equipment.
5. test jumper with standard fibre optical signal optical power meter connected to the device's output, the output optical power measuring device, confirming its output optical power and the front panel display the same value, and the nominal value has been reached. (When measuring optical power, optical power meter should be recognized under the 1550nm wavelength measurement document, confirm that the fiber optic test jumpers to match standard test jumper, Union joint surface and pollution-free.) Removal of standard fibre optic test jumpers and optical power meter, devices connected to the network. At this point, the device has finished installation and commissioning.

VIII. after-sales service

1. I promise: products are free warranty for 13 months (to paste the factory serial number on the side of the device is identified by the factory starting time of day), and lifelong maintenance. Due to user misuse or irresistible natural factors caused by equipment failure, we will only be responsible for the maintenance, material costs and charge the appropriate fee.
2. If the device fails, you should immediately contact your local dealer, or call our customer service center.
3. Fault device requires action by professional technicians on-site, so as to avoid equipment damage.
4. **Special Note:** for devices that was to open the maintenance by the user, our company will not be free warranty, only to the warranty and reasonable maintenance costs and material costs will be charged.

Cleaning and maintenance method for fiber optic connector

And a lot of times, we will drop light power outlet misjudgments for optical equipment failure, the actual fiber optic connector may be caused by dust or dirt, pollution, just proper cleaning and maintenance of fiber optic connector, you can troubleshoot. Below introduce operation method of cleaning and maintenance of fiber optic connector.

1. power off the device, carefully unscrew the fibre on activities from the adapter connector
2. with texture good lens tissue or carefully with a degreasing alcohol cotton light connector cleaning; such as degreasing alcohol cotton cleaning, cleaning is complete, also 1-2 minutes, let dry alcohol flavor of the active connector surface
3. cleaning out fiber optic connection socket, access optical power meter, measuring output optical power, to confirm that the fiber optic connector has been cleaned.
4. clean the fiber optic connector back to the adapter, should pay attention to appropriate, in order to avoid too much force lets the adapter internal ceramic pipe rupture.
5. fiber optic connector after cleaning, the output light power is not normal, you should remove the adapter, unscrew another connector to clean it inside the machine; such as cleaning after the optical power remains low, at which point adapter might be contaminated, cleaning with the adapter. (Note: use caution when you remove the adapter operation in order to avoid damages fibers inside the machine.)
6. dedicated compressed air available for adapter cleaning or degreasing cleaning alcohol cotton section. With compressed air cleaning, compressed air nozzles of gas tank at the adapter of ceramic pipes, ceramic tubes blowing compressed air into clean; with fat alcohol cotton cleaning, carefully into the alcohol cotton ceramic pipe cleaning. Attention alcohol cotton into the direction of articles should always be consistent, otherwise may not be able to reach the ideal cleaning effect.

Pay special attention to

- A. in the cleaning operation of fiber optic connector should be avoided with optical connection diagram on the human body or human eyes, so as to avoid causing wing damage on the human body or human eyes permanently burn!!!
- B. installing fiber optic connector, force should be appropriate, failure to do so may cause the adapter in the ceramic fragments. Ceramic Tubes once the fragmentation, the output light power will drop significantly, turning it slightly and fiber-optic connector, the output light

power will be significantly changed.

- C. any operation on the fiber, without turning on the pump laser, or high power output causes the output fibre connector is burned out, thus giving rise to the output power is reduced.

Such as equipment changes lead to a section in this manual do not match, are subject to change without notice.